

Art. No.
1053



ZOLOTO®
BRONZE
Y-TYPE
STRAINER
(Screwed)



SALIENT FEATURES :

- Screwed Female ends to BSPT.
- Stainless Steel/ Brass 1 mm hole diameter perforated sheet screen is guided in the body & cover.
- Fine finish and smooth contours reduce pressure drop in the strainer.
- Large screening area makes the strainer efficient in performance.

SUITABLE FOR

Steam	Water	Oil	Air	Gases
◆	◆			

MATERIALS :

Name of Part	Material	Specification
Body	Bronze	IBR 282 (a) (iv) Gr. B
Cover	Bronze	IBR 282 (a) (iv) Gr. B
Gasket	Steam Jointing Sheet	IS 2712 Gr. W/3
Screen	S.S/ Brass	AISI 304/ IS 410

SIZE:

Inches	mm	A	B
1/2	15	76	52
3/4	20	98	67
1	25	133	85
1¼	32	152	98
1½	40	178	116
2	50	222	140

DIMENSIONS:

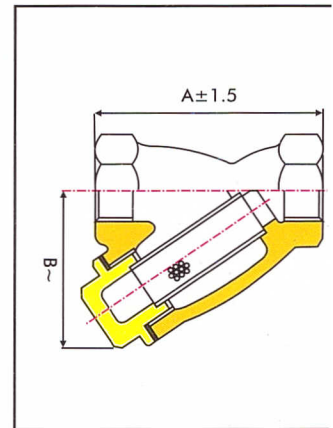

Test Pressure (Hydraulic) 35.15kg/cm²g (500psig) Working Pressure (Steam) 17.58kg/cm²g (250psig) Max. Working Temperature 225°

Art. No.
1054

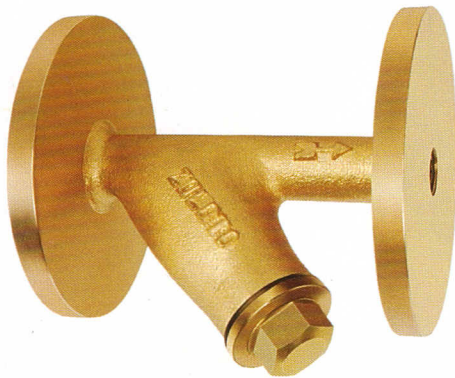

ZOLOTO®
BRONZE
Y-TYPE
STRAINER
(Flanged)



SALIENT FEATURES :

- Flanged ends to BS 10 Table 'H'.
- Stainless Steel/ Brass 1 mm hole diameter perforated sheet screen is guided in the body & cover.
- Fine finish smooth contours reduce pressure drop in the strainer.
- Large screening area makes the strainer efficient in performance.

SUITABLE FOR

Steam	Water	Oil	Air	Gases
◆	◆			

MATERIALS :

Name of Part	Material	Specification
Body	Bronze	IBR 282 (a) (iv) Gr. B
Cover	Bronze	IBR 282 (a) (iv) Gr. B
Gasket	Steam Jointing Sheet	IS 2712 Gr. W/3
Screen	S.S/ Brass	AISI 304/ IS 410

SIZE:

Inches	mm	A	B
1/2	15	136	68
3/4	20	140	85
1	25	162	110
1¼	32	178	120
1½	40	203	145
2	50	203	188

DIMENSIONS:

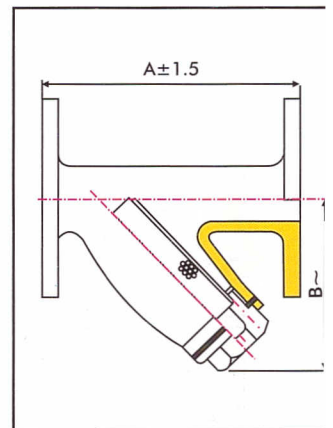

Test Pressure (Hydraulic) 35.15kg/cm²g (500psig) Working Pressure (Steam) 17.58kg/cm²g (250psig) Max. Working Temperature 225°